

# Kenco Engineering, Inc.

Wear Parts for Material Transfer Vehicles

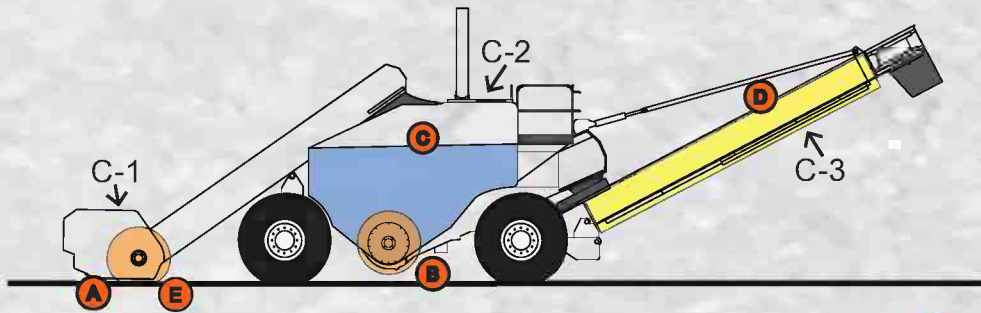

- Kenco now has Tungsten Carbide Impregnated augers for both C-1 **A** and C-2 **B** !
- Kenco provides maximum wearlife with fewer change outs and minimum downtime.
- Kenco TCI cutting edges are also available for windrow model machines. **E**



- Protect your C-2 hopper **C** better and faster with Kenco Heavy Duty Wear Patch.
- Combine WP-570-38 with our new WP-812-38 for complete coverage.
- Use Kenco KWS-12-ATC TCI wear strips to protect the top ridges.



- Kenco now offers a direct bolt-on replacement for C-3 **D** floor!
- This floor carries the same "5 year guarantee" as our paver floors.
- AR side liners are also available.

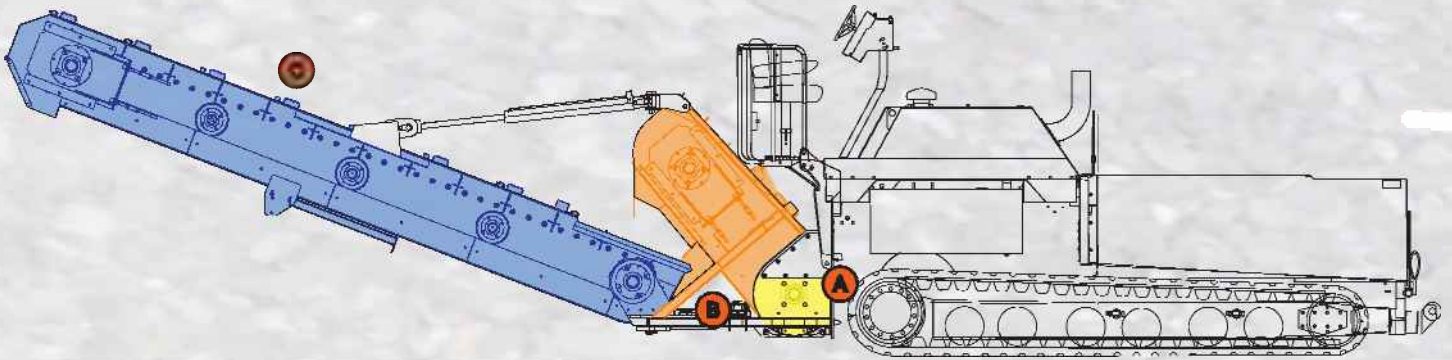

- Kenco now has Tungsten Carbide Impregnated Kicker Paddles and Ribbon Augers for the CR662 remix system (A)
- Customers report dramatically longer wearlife than OEM components.

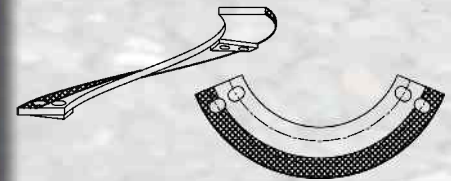

- Kenco offers our unique modular liner system for the lift conveyor (B)
- Kit includes “Alloy-K” wear plates mounted to a studded backing plate for non-impact areas and studded wear plates with full TCI coverage for impact zones.
- Kenco liners carry our unique “5 year guarantee” and offer a dramatic improvement over factory AR liners

- Kenco’s “Alloy-K” liners for the load-out conveyor (C) offer a drop-in replacement solution for longer wearlife.
- Conveyor liners are also covered by Kenco’s “5 year guarantee”.
- Please see our web site for more details.



Distributed by:



Kenco Engineering, Inc.  
 P.O. Box 1467  
 Roseville, CA 95678  
 800-363-9859  
 www.kencoengineering.com